



Torque Wrench

TU SERIES SPECIFICATION (Square Drive)

Technical

Model Number	TU-2	TU-3	TU-7	TU-11	TU-27	TU-60
Square Drive	3/4"	1"	1-1/2"	1-1/2"	2-1/2"	2-1/2"
Min. Torque (Ft/Lbs)	127	330	740	1,100	2,720	5,800
Max. Torque (Ft/Lbs)	1,270	3,330	7,400	11,010	27,200	58,000
Output Accuracy	+/-3%	+/-3%	+/-3%	+/-3%	+/-3%	+/-3%
Repeatability	100%	100%	100%	100%	100%	100%
Duty Cycle	100%	100%	100%	100%	100%	100%
Tool Weight (Lbs)	3.90	9.00	19.00	29.00	70.00	130.00

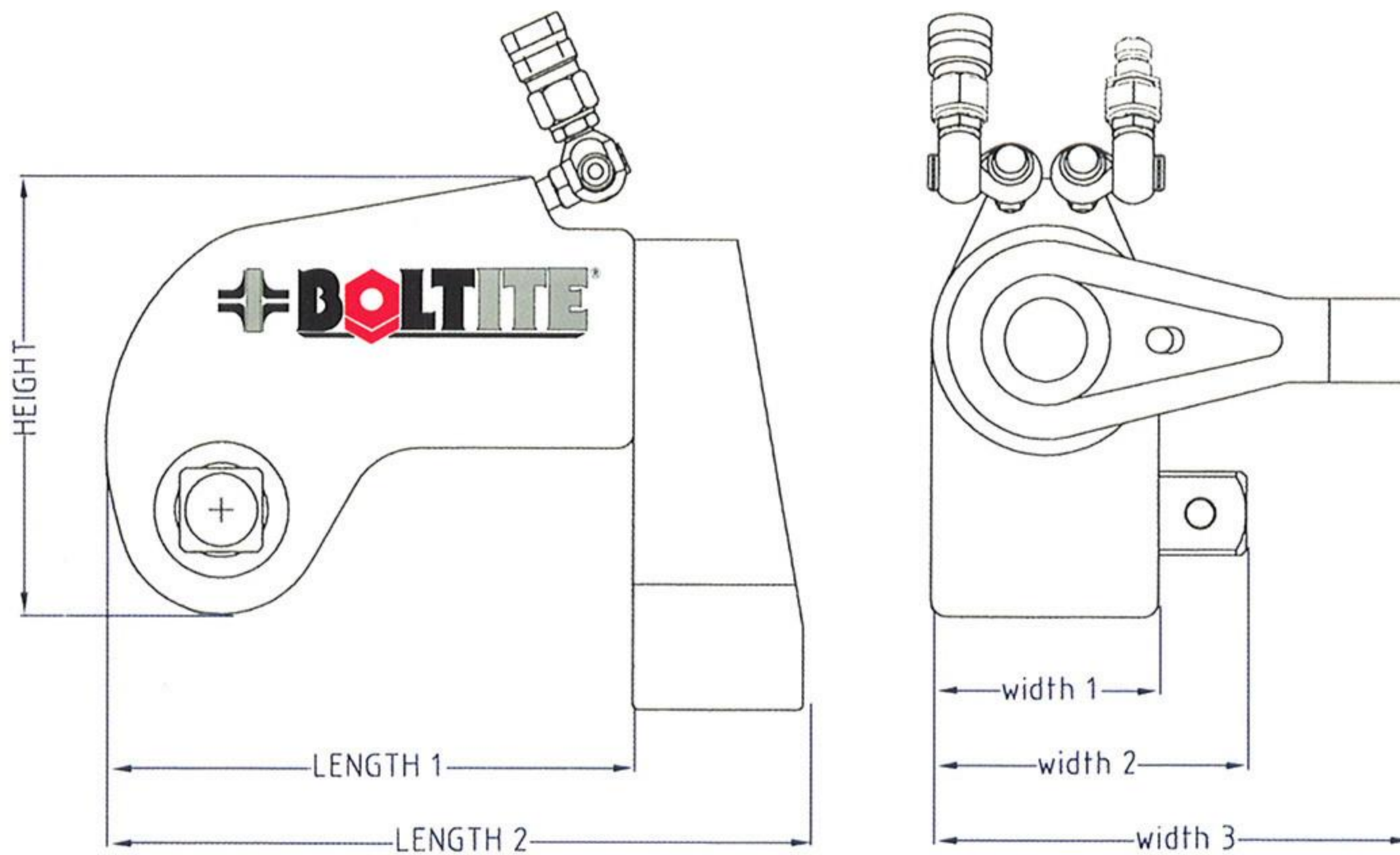

Dimensions

Model Number	TU-2	TU-3	TU-7	TU-11	TU-27	TU-60
Height	4.20	5.30	6.99	7.79	10.19	11.50
Length 1	4.68	6.10	8.00	9.21	12.29	15.38
Length 2	6.20	8.10	10.74	12.21	16.29	20.40
Radius	0.98	1.30	1.70	1.95	2.43	2.90
Width 1	2.00	2.62	3.61	3.93	5.26	6.58
Width 2	2.79	3.68	5.06	5.43	7.73	8.89
Width 3	4.42	5.81	7.98	8.72	11.63	14.29

Note:

All Tool Weights Include Couplers, Swivels, Reaction Arm and Internal Oil.

The Patented Mono-Body Housing Is Standard On All Models.

All Dimensions are in Inches.

